

# HFDN-30.0 Designing for 10Gbase-CX4 Transmitter Template Compliance with the MAX3983

*The MAX3983 cable driver/receiver was optimized to achieve maximum cable span without the use of automatic/adaptive equalization techniques. After its release new copper cable interface standards were completed, the most stringent of which are found in the IEEE802.3's 10Gbase-CX4 transmitter output template. This discussion will aid in achieving CX4 compliance using the MAX3983. With the addition of a few passive components, the high performance MAX3983 can easily be adjusted to meet this tight template.*

## Transmission Requirements

10Gbase-CX4 requires that the transient response of the cable transmitter fit within the upper and lower limits of a template. The template has been devised to capture the simultaneous effects of transition time, pre-emphasis level, peak-to-peak voltage, logic one and zero voltages, and aberrations such as ringing and reflections. The MAX3983 offers adjustable pre-emphasis but offers neither adjustable voltage swing nor adjustable transition time. All of these are factors that determine the fit of the output waveform to the 10Gbase-CX4 template. Figure 1 is the template as described in the February 2004 release of the 10Gbase-CX4 standard.

Figure 2 shows how the MAX3983 transmitter compares to the template using a pre-emphasis setting that is near but larger than the template limits.

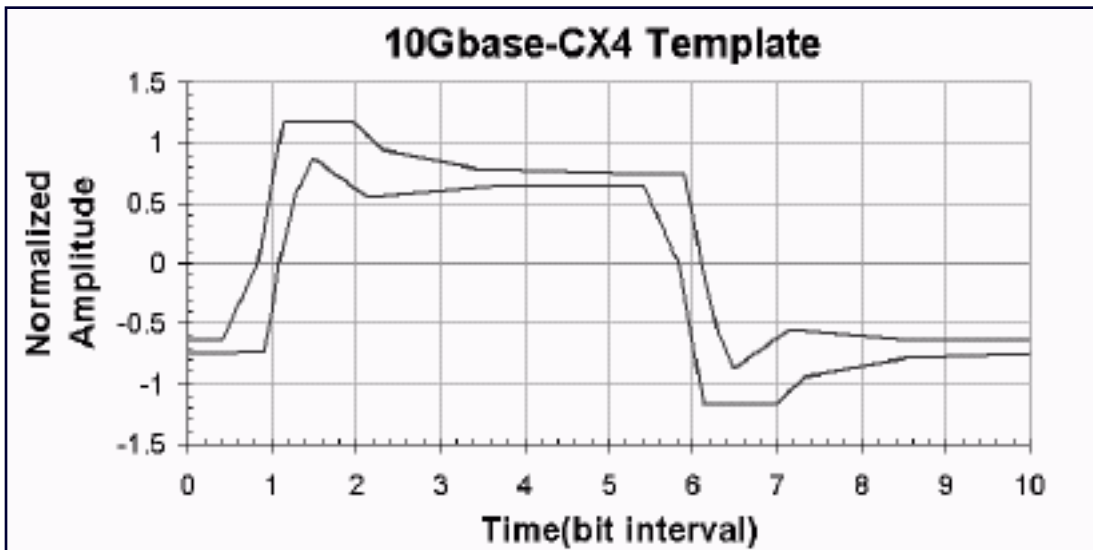

Figure 1. Upper and lower limits as prescribed by the IEEE802.3's 10Gbase-CX4.

The MAX3983 pre-emphasis setting used in Figure 2 is TXPE1=logic zero and TXPE0=logic one. This results in approximately 6dB of compensation. In other words, the ratio of the peak-to-peak voltage to the logic zero-to-one voltage is 2-to-1. With a little excess in peak-to-peak voltage, it will be possible to slow the transition time and reduce the peak-to-peak voltage to fit within the limits.

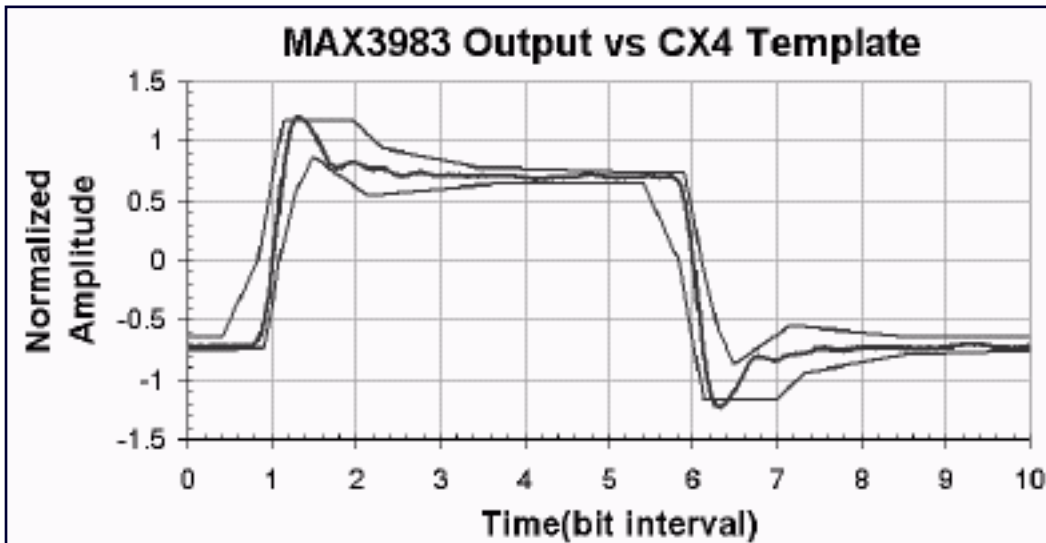

Figure 2. MAX3983 transmitter output (without modification and with PE=6dB) compared to the 10Gbase-CX4 template.

## Design Methodology

The first step to compliance is adjusting the transition time. The minimum (fastest) transition time allowed by 10Gbase-CX4 is 60ps, but the MAX3983 transition time is approximately 35ps at the chip. A lossy transmission line can be introduced between the chip and the cable connector to lengthen the transition time to 60ps; however, this might be excessively long and pose a hardship where board space is a premium. For this discussion, an FR4 transmission line of 1.5inches will be included that will lengthen the time to 50ps, but further lengthening is required.

Simply placing a shunt capacitor is not the answer. This actually creates new problems because it completely ruins the output return loss, which is carefully specified and governed by the 10Gbase-CX4 document. With the shunt capacitor in place, the output impedance is restored with a series resistor added to each half of the differential output. This has the added effect of further lowering the output peak-to-peak voltage. This combination of shunt C and series R can be selected to adjust the transition time and output level while maintaining an acceptable return loss. Figure 3 illustrates the concept.

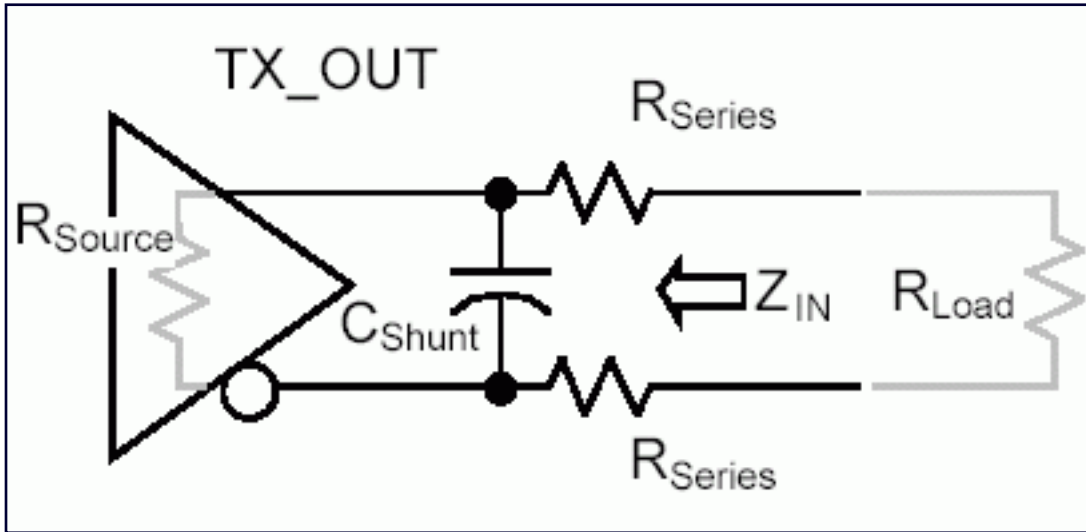

Figure 3. Adding a shunt C and series R will simultaneously increase the transition time and lower the peak-to-peak voltage while maintaining acceptable output impedance.

## Choosing the Shunt C and Series R

Selection of the shunt capacitance is determined by the minimum transition time (20%-80%) requirement for the application. The MAX3983 produces a 35ps transition time at the chip. After 1.5inches of FR4, the transition time is approximately 50ps. CX4 requires that the minimum be no less than 60ps. Equation (1) below gives a good place to start for  $C_{SHUNT}$ , but it does not account for all circuit board losses and other parasitic reactance.

The useful range for R is between 10 and 20 ohms and the useful range for  $C_{SHUNT}$  is between 0.5pF and 0.75pF.

$$C_{SHUNT} = \frac{\sqrt{t_R^2 - t_{MAX3983}^2}}{2\pi R(0.2)} \quad \text{eq (1)}$$

Where

$t_R$  is the desired system 20%-80% transition time.

$t_{MAX3983}$  is 50ps, the typical 20%-80% transition time of the MAX3983 after 1.5inches of FR4.

$R$  is the equivalent parallel resistance,  $R_{SOURCE} || (2R_{SERIES} + R_{LOAD})$ .

The nominal value for the series R can be computed to produce the correct impedance of 100ohms at an arbitrary frequency such as 1.0GHz.

$$R_{SERIES} = \left( Z_{IN} - \left( \frac{1}{\frac{1}{R_{SOURCE}} + 2\pi f C_{SHUNT}} \right) \right) \div 2 \quad \text{eq(2)}$$

Where

$Z_{IN}$  is the desired impedance of 100ohms at frequency  $f$ .

$C_{SHUNT}$  is the shunt capacitance.

$R_{SOURCE}$  is the transmitter impedance of 100ohms.

$f$  is the frequency at which the  $Z_{IN}$  is 100ohms.

The resistor  $R_{SERIES}$  has an additional impact on the transient response besides mitigating impedance mismatching.  $R_{SERIES}$  also reduces the output swing. The 10Gbase-CX4 committee established the maximum allowed output at 1200mV<sub>PP</sub>. Because the MAX3983 has a typical output of 1500mV<sub>PP</sub>, it requires an adjustment to comply with the CX4's 1200mV<sub>PP</sub> maximum output. The value of  $R_{SERIES}$  can be varied a few ohms without a significant impedance change to give some adjustment of the peak-to-peak output.

## Results

Table 1 below is a summary of results using different  $R_{SERIES}$  and  $C_{SHUNT}$  values. The transition time is measured using the logic zero as the 0% reference and the pre-emphasis peak (after the zero-to-one transition) as the 100% reference.

**Table 1. Table 1. Results for different  $R_{SERIES}$  and  $C_{SHUNT}$**

$R_{SERIES}$ , $C_{SHUNT}$	Peak-to-Peak Output	20%-80% Transition time
12ohm, 0.51pF	1.25V	70ps
14ohm, 0.62pF	1.20V	74ps
16ohm, 0.72pF	1.14V	76ps
18ohm, 0.86pF	1.08V	79ps

20ohm, 1.0pF

1.02V

83ps

Figure 4 shows the MAX3983 output compared with the CX4 transmitter mask where  $R_{\text{SERIES}} = 12\text{ohms}$  and  $C_{\text{SHUNT}} = 0.5\text{pF}$ . Now the transient response meets the transition time and peak-to-peak requirements while delivering the maximum allowed pre-emphasis.

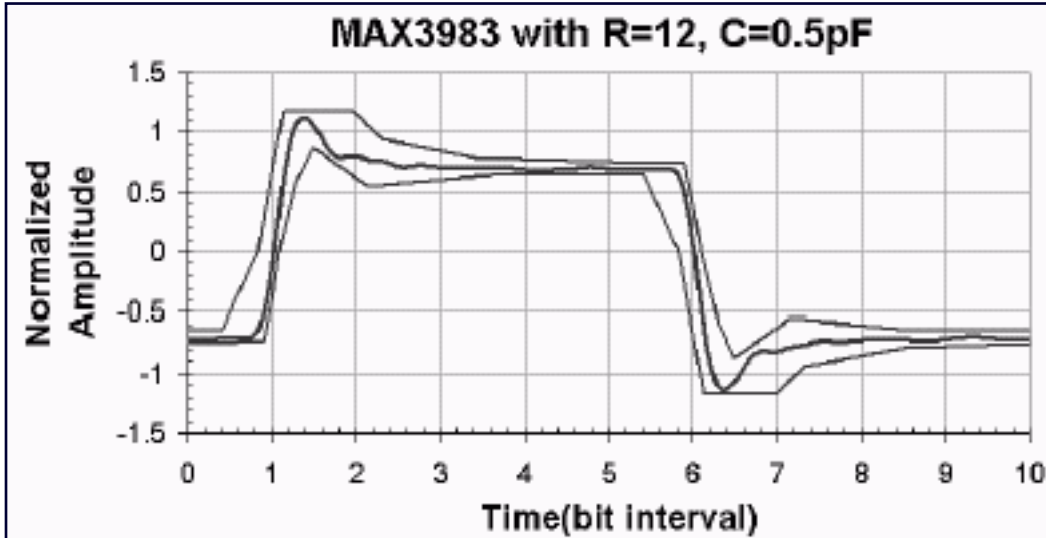

Figure 4. MAX3983 output meets CX4 requirements using external  $R$  and  $C$ .

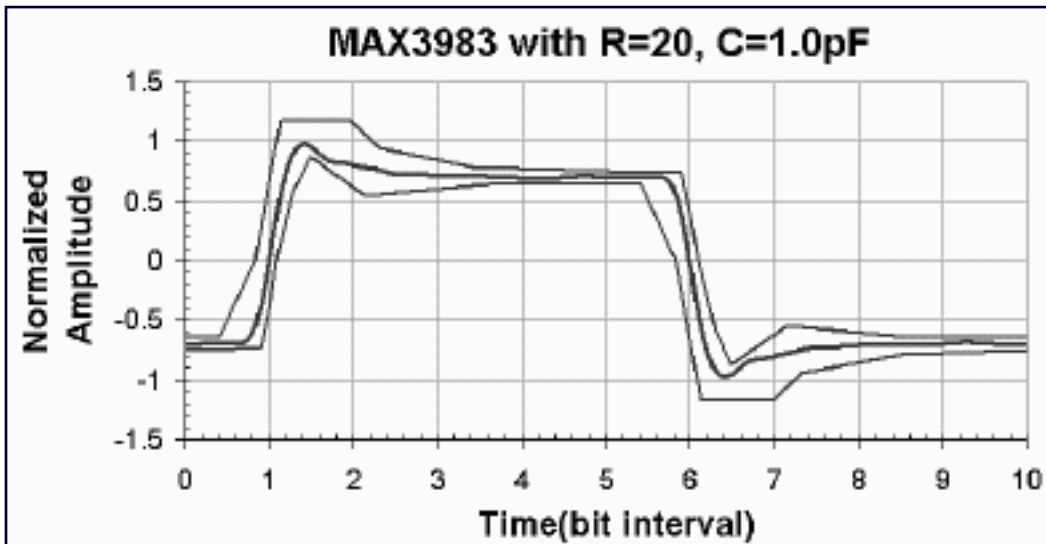

Figure 5. MAX3983 output meets CX4 requirements but has sacrificed too much pre-emphasis.

Armed with several possibilities to meet the CX4 template, the output return loss is the last requirement to meet. Figure 6 shows the output return loss of four  $R_{\text{SERIES}}$  and  $C_{\text{SHUNT}}$  combinations added to the MAX3983. For all of the examples, 15dB or better return loss was measured below 2GHz. This is significantly better than the 10dB minimum required by CX4.

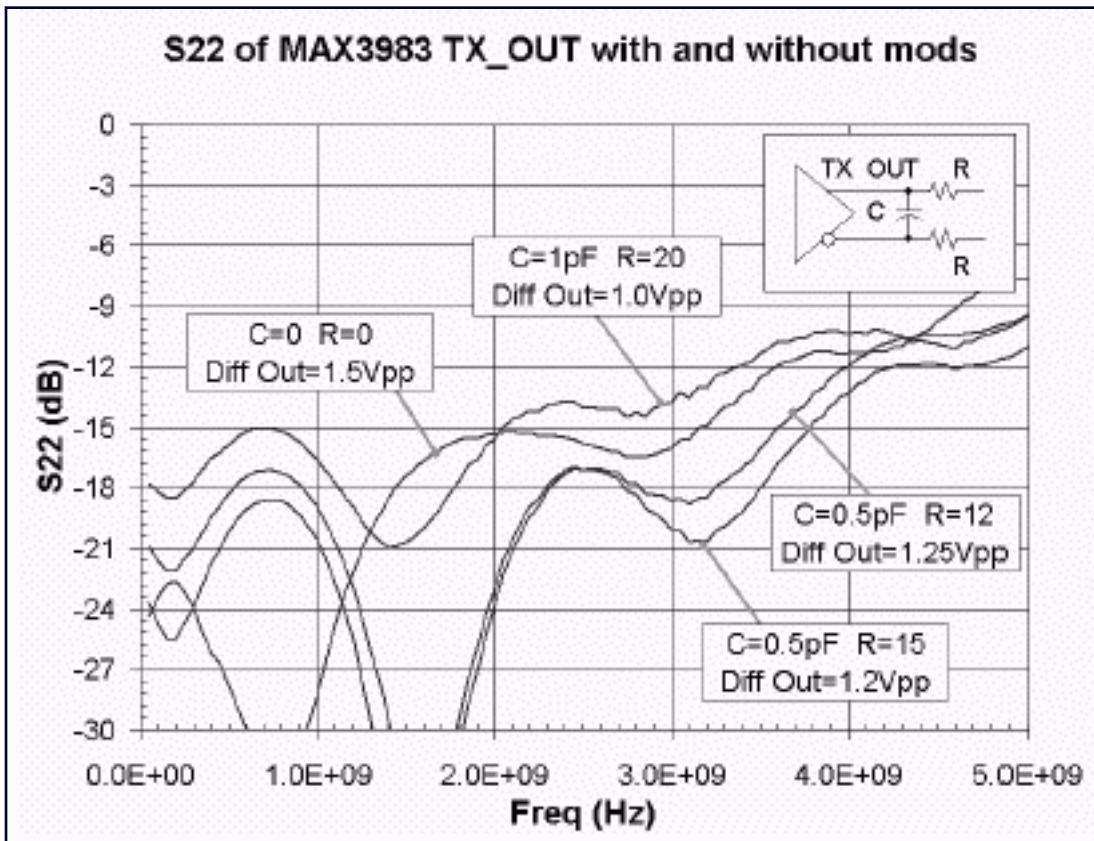

Figure 6. Output return loss due of different  $R_{SERIES}$  and  $C_{SHUNT}$  values.

## Conclusion

The MAX3983 is a versatile cable equalizer that can be used for a variety of applications. The design methodology discussed here is a very simple and effective way to make fine adjustments to the transient response. It is clear that a trivial RC network is all that is needed to bring the MAX3983 transmitter transient response into compliance with 10Gbase-CX4.

## More Information

MAX3983: [QuickView](#) -- [Full \(PDF\) Data Sheet](#) -- [Free Samples](#)